

TWIN GATE 2

SOLID AND ELEGANT

TWIN GATE 2 has a solid and elegant gate body with high level security. The simple and sophisticated design suit best to the security of the office environment.

After accessing the card reader with ID, only the permitted user can go through the lane. Furthermore, the slide panels do not allow the outsider to open the panels by force.

FEATURES

Established security and safety

TWIN GATE 2 has the tailgating detection sensor which checks the unauthorized user from going through the gate forcibly.

The parts for slide glass panels have also the sensor which helps user not to get caught between the panels.

Two types of aisle

The aisle width from 600 mm or 900mm is selectable.

600 mm type is standard width. 900 mm type can be used for the wheelchair user and the person who handle a carriage or wagon.

Selectable Slide panel height

The height of slide panel is selectable from 1200 mm or 1800 mm.

If you select 1800mm flap-panel, no one can jump over the gate easily.

The 1200mm flap-panels create an elegant appearance in the office space.

Easy to replace

It is easy to replace the existing TWIN GATE installed in the past for TWIN GATE 2, without too much work. The additional floor work is not necessary, and the existing floor anchors and pipes can be used for the replacement.



Selectable Access Indication

There are two kinds of access indications. The single row type is stylish, and the arrow type can be recognized easily.



single row type



arrow type

TWIN GATE 2



■ front view

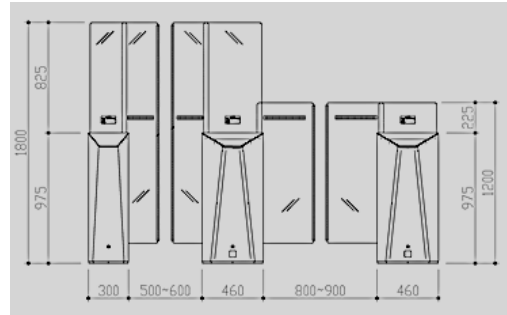

■ side view

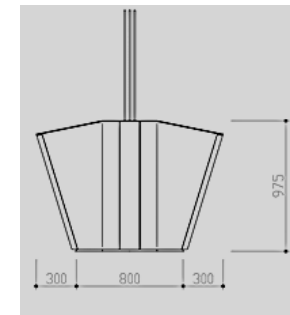

■ above view

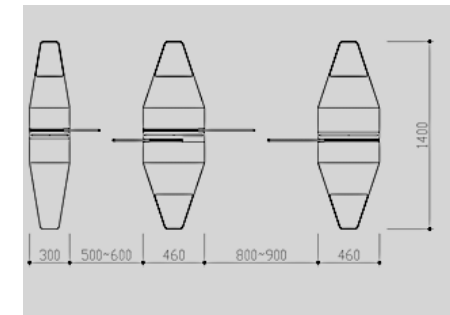

Card reader	Not included
Direction	Both directions
Capacity	25 people/ min. Automatic door mode : Max.50 people
Necessary time to open/ close	Standard(narrow) aisle : Changeable within the range 1.35 - 2.0 sec. Wide aisle : Changeable within the range 1.5 - 2.9 sec.
Dimensions for gate body	Standard(narrow) type : W300 x H975 x D1,400 mm Wide type : W460 x H975 x D1,400 mm
Panel height	1,200 mm/ 1,800 mm over the floor
Dimension of aisles	Standard(narrow) aisle : Changeable within the range 500 - 600 mm Wide aisle : Changeable within the range 800 - 900 mm
Main materials	Body : Stainless steel, Polycarbonate, Acrylic acid resin, Tempered clear glass Structural members : Galvanizing steel plate, Structural steel, Stainless steel Slide panel/ Fixed panel : Tempered clear glass
Finish	Stainless : Hairline finish
Power	AC200V-240V 50/ 60Hz with grounding / AC90V-110V 50/ 60Hz with grounding
Consuming power	Not in use : 24.2W/49.2VA In use : 53.5W/111.8VA (Optional parts are not included)
Power failure	Flap panels can be opened easily with your hands
Operation temperature	0 - 40°C Humidity : no condensing
Installation	Indoor